

CQM74x Wi-Fi 6/BT/15.4 Module

– Powered by Qualcomm QCC744/QCC748

Documentation Title	Documentation No	Revision	Classification	Status	Date
CQM74x Wi-Fi 6/BT/15.4 Module Datasheet		V1.2	Public	Release	Mar 18, 2025

Table of Contents

1	<i>Product Overview</i>	4
2	<i>Hardware Specification</i>	7
2.1	Block Diagram	7
2.2	Pinout Description	8
2.2.1	Pin Map	8
2.2.2	Pin Definition	9
2.2.3	I/O Pin Mux Table	11
2.3	Computing Subsystem	12
3	<i>Electrical Characteristics</i>	13
3.1	Absolute Maximum Ratings	13
3.2	Recommended Operating Conditions	13
4	<i>Radio Performance</i>	14
4.1	802.11b/g/n/ax (Wi-Fi 6)	14
4.2	Bluetooth	15
4.3	802.15.4	15
5	<i>Power Consumption</i>	16
6	<i>Mechanical Specification</i>	17
6.1	Pin Antenna	17
6.1.1	Dimension.....	17
6.1.2	Recommended PCB Landing Pattern	17
6.2	PCB Antenna	18
6.2.1	Dimension.....	18
6.2.2	Recommended PCB Landing Pattern	18

Documentation Title	Documentation No	Revision	Classification	Status	Date
CQM74x Wi-Fi 6/BT/15.4 Module Datasheet		V1.2	Public	Release	Mar 18, 2025

6.3	Connector Antenna	19
6.3.1	Dimension.....	19
6.3.2	Recommended PCB Landing Pattern	19
7	<i>Manufacturing Recommendation.....</i>	20
7.1	Power Layout Guideline	20
7.2	Soldering Recommendations.....	20

Documentation Title	Documentation No	Revision	Classification	Status	Date
CQM74x Wi-Fi 6/BT/15.4 Module Datasheet		V1.2	Public	Release	Mar 18, 2025

1 Product Overview

Powered by Qualcomm high performance 1x1 2.4GHz Wi-Fi 6/BT/15.4 combo all-in-one SoC QCC744/QCC748, CQM74x IoT connectivity LGA module portfolio is purposefully designed to pack processing capabilities, Wi-Fi/BT/15.4 combo connectivity, and on-module memory into a single 44-pin LGA form factor with flexible choices of Pin, PCB and U.FL antenna. All variant antenna modules are pin compatible, allowing easy swap among modules. Its 1.27mm (0.05") pitch design enables a seamless conversion from LGA pads to standard 1.27mm (0.05") headers, allowing for field-replaceable header modules if needed.

Unlike other Wi-Fi/BT/15.4 combo modules on the market, CQM74x has integrated powerful 32-bit RISC-V processor with FPU and DSP running up to 325MHz, on-chip 484KB SRAM and 128KB ROM, multimedia features such as audio and video codec and interfaces, and 35x multiplexed GPIO rich peripherals. Its all-in-one design and capability contribute to reduced costs and enhanced performance, making it an attractive choice for IoT edge devices requiring single chip solution.

CQM74x operates in hostless mode, capable of running both the protocol stack all the way to application level as well as IoT applications without requiring an external MCU. Built on FreeRTOS, Its software SDK will be open-sourced on GitHub coupled with VS Code IDE market extension to facilitate rapid IoT application development. It can also be used as an IoT connectivity transceiver in hosted mode with an external host running all upper protocol stacks and applications.

CQM74x includes the following configurations:

Module	Form Factor	Antenna
CQM744-0-50-0P	16 x 16 x 2.2 mm, 1.27 mm pitch, 44-pin, LGA	Pin Antenna
CQM744-0-50-0B	16 x 21 x 2.2 mm, 1.27 mm pitch, 44-pin, LGA	PCB Antenna
CQM744-0-50-0U	16 x 16 x 2.2 mm, 1.27 mm pitch, 44-pin, LGA	U.FL Antenna
CQM748-0-50-0P	16 x 16 x 2.2 mm, 1.27 mm pitch, 44-pin, LGA	Pin Antenna
CQM748-0-50-0B	16 x 21 x 2.2 mm, 1.27 mm pitch, 44-pin, LGA	PCB Antenna
CQM748-0-50-0U	16 x 16 x 2.2 mm, 1.27 mm pitch, 44-pin, LGA	U.FL Antenna

Documentation Title	Documentation No	Revision	Classification	Status	Date
CQM74x Wi-Fi 6/BT/15.4 Module Datasheet		V1.2	Public	Release	Mar 18, 2025

CQM74x is graphically illustrated below:

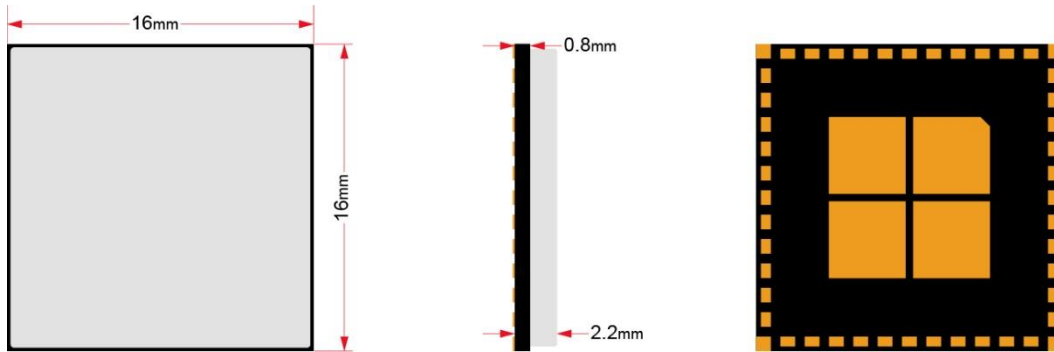

Figure 1: CQM74x-0-50-0P Module View

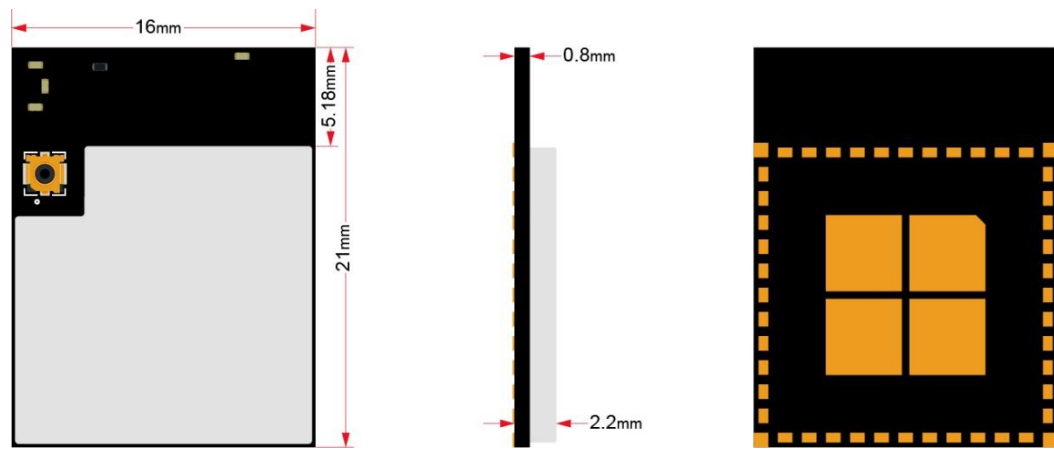

Figure 2: CQM74x-0-50-0B Module View

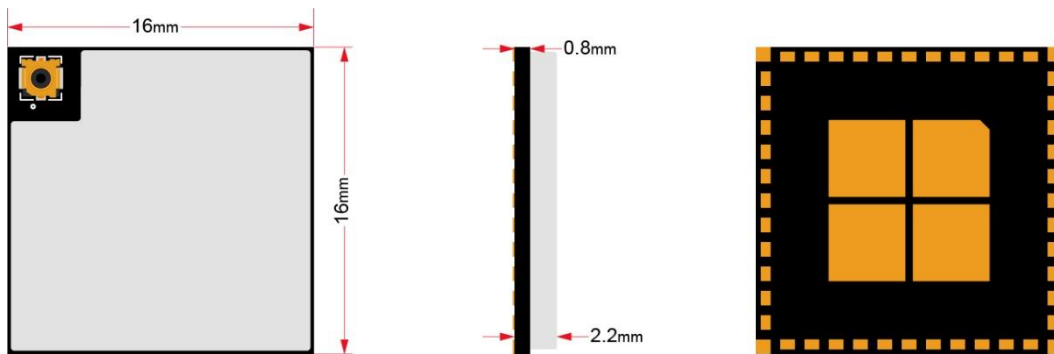

Figure 3: CQM74x-0-50-0U Module View

Documentation Title	Documentation No	Revision	Classification	Status	Date
CQM74x Wi-Fi 6/BT/15.4 Module Datasheet		V1.2	Public	Release	Mar 18, 2025

The CQM74x specific development kits are also provided to facilitate application software development as shown below:

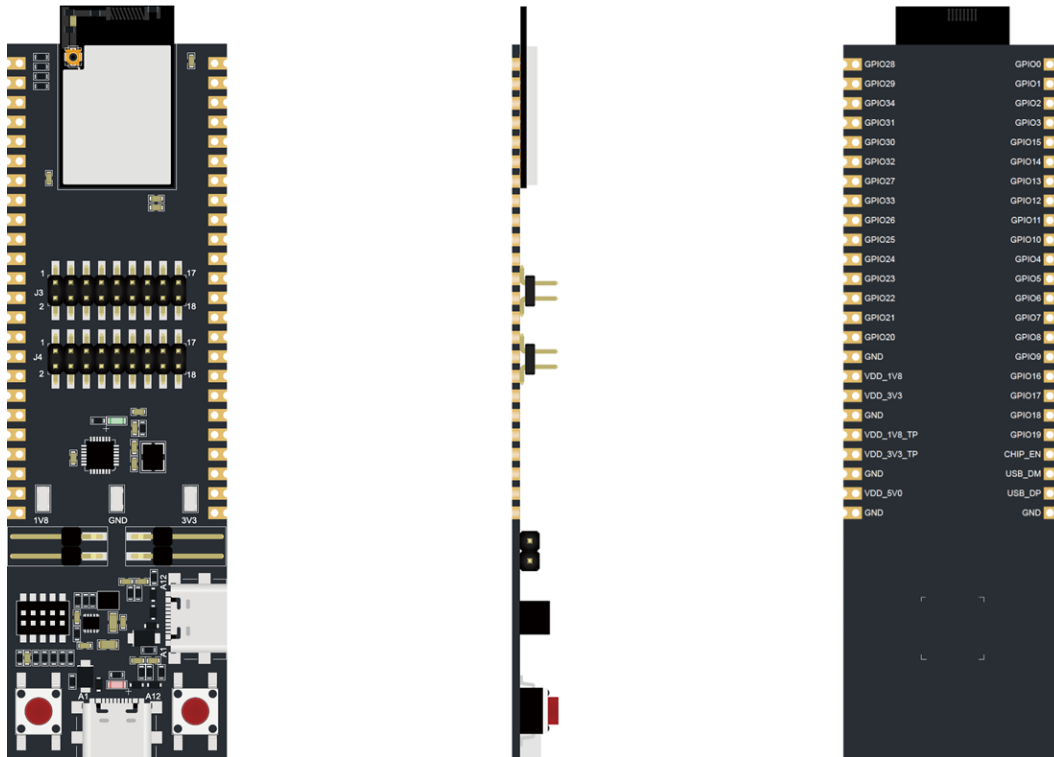

Figure 4: CQM74x Module Development Kit

Documentation Title	Documentation No	Revision	Classification	Status	Date
CQM74x Wi-Fi 6/BT/15.4 Module Datasheet		V1.2	Public	Release	Mar 18, 2025

2 Hardware Specification

This section provides detailed hardware design and specification of CQM74x. CQM74x hardware design has been optimized for small footprint and reduced RBOM cost.

2.1 Block Diagram

CQM74x integrates 8MB NOR flash and optional 32.768kHz RTC crystal. The design also supports PCB antenna (CQM74x-0-50-0B) or simply provides antenna pin (CQM74x-0-50-0U) to allow customized antenna implementation on motherboard. The block diagram is shown below.

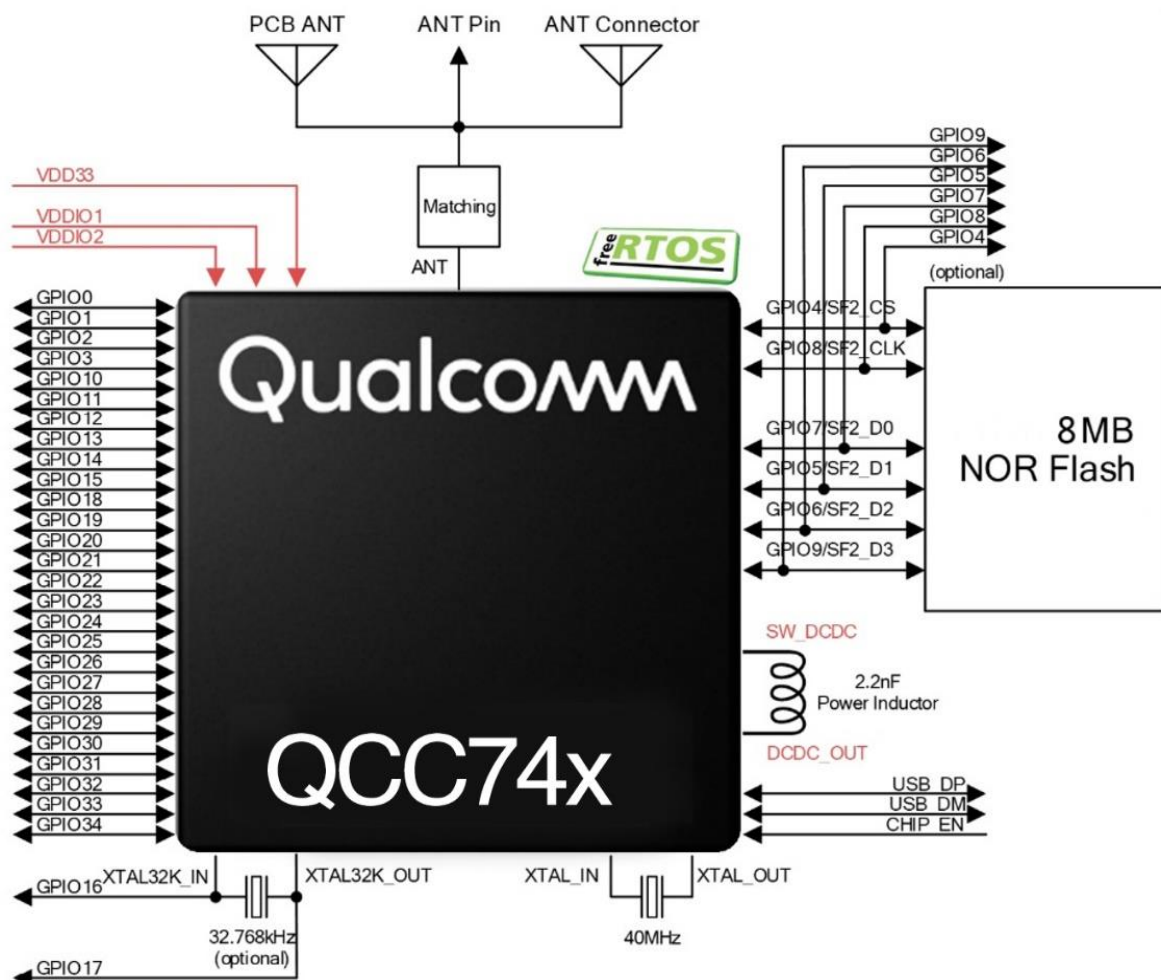

Figure 5: CQM74x Module Block Diagram

Documentation Title	Documentation No	Revision	Classification	Status	Date
CQM74x Wi-Fi 6/BT/15.4 Module Datasheet		V1.2	Public	Release	Mar 18, 2025

2.2 Pinout Description

2.2.1 Pin Map

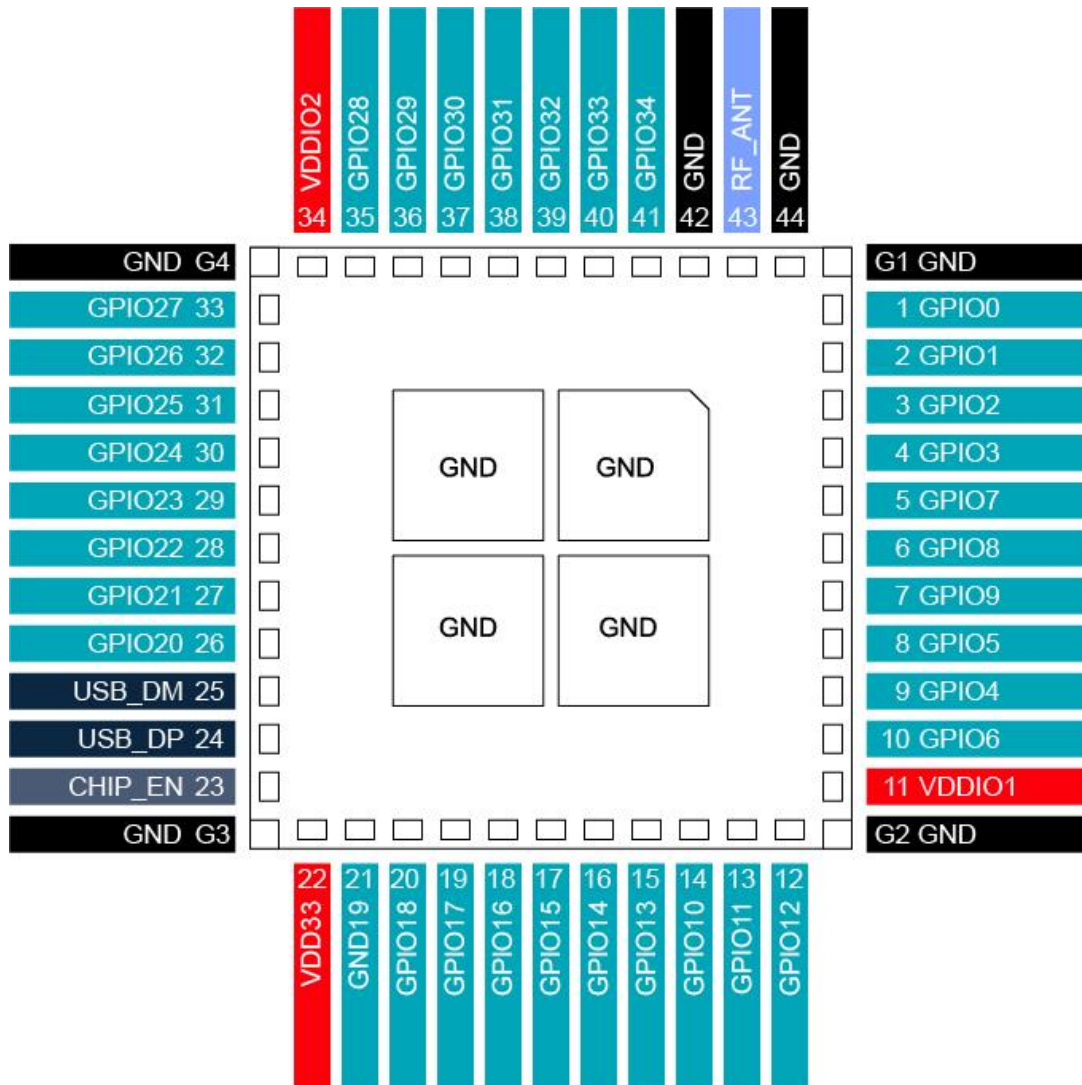

Figure 6: CQM74x-0-50-0P Module Pin Map

Documentation Title	Documentation No	Revision	Classification	Status	Date
CQM74x Wi-Fi 6/BT/15.4 Module Datasheet		V1.2	Public	Release	Mar 18, 2025

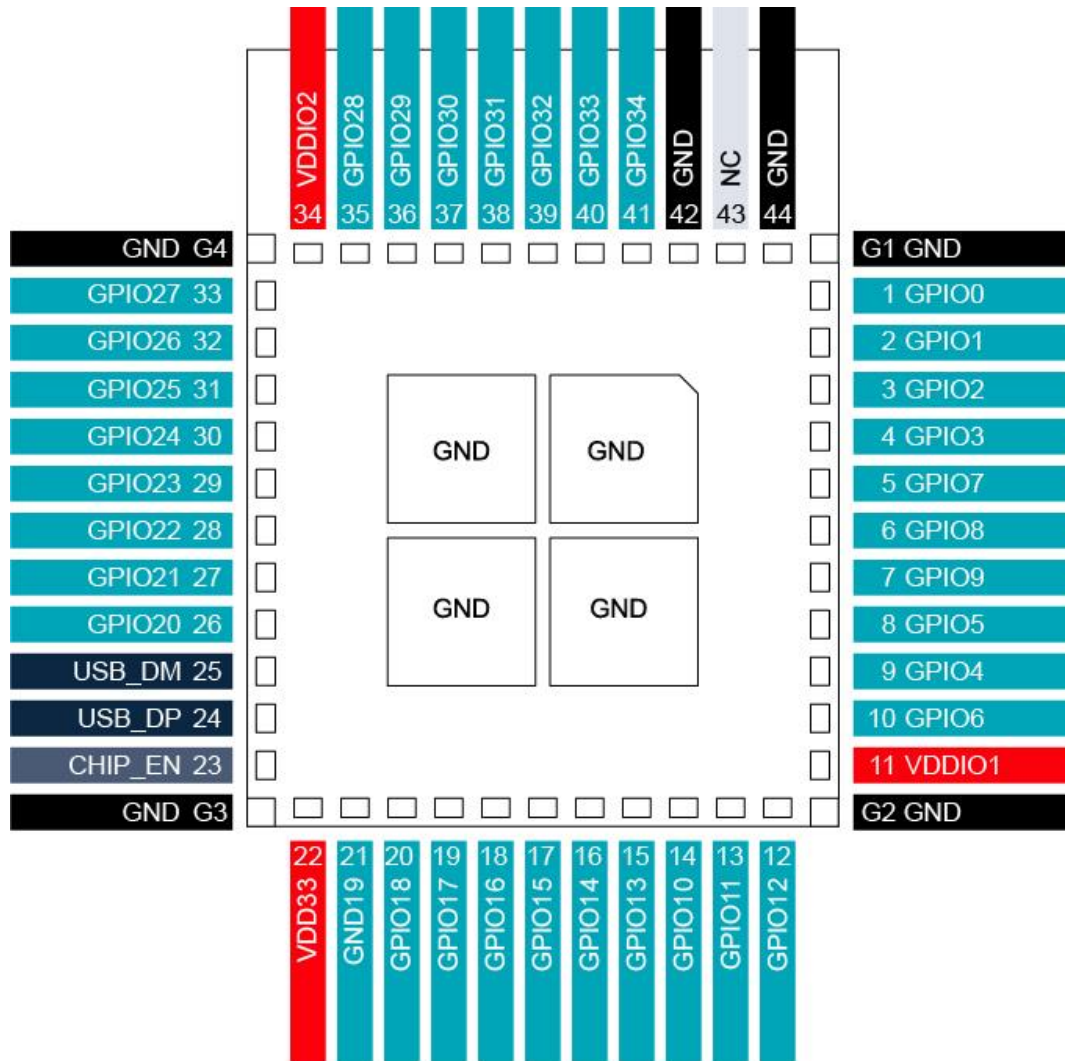

Figure 7: CQM74x-0-50-0B/U Module Pin Map

2.2.2 Pin Definition

Pin	Pin Name	Type	Power Domain	Description
22	VDD33	PWR	-	Power input (2.97~3.63V)
11	VDDIO1	PWR	-	Host I/O voltage input GPIO0~15
34	VDDIO2	PWR	-	Host I/O voltage input GPIO20~34
G1-G4,42,44	GND	GND	GND	Ground
43	RF_ANT	AI/AO	-	Pin antenna(CQM74x-0-50-0P)
	NC	-	-	No Connection(CQM74x-0-50-0B/U)
24	USB_DP	AI/AO	-	USB Data+(CQM748-0-50-0P/B/U support)

Documentation Title	Documentation No	Revision	Classification	Status	Date
CQM74x Wi-Fi 6/BT/15.4 Module Datasheet		V1.2	Public	Release	Mar 18, 2025

25	USB_DM	AI/AO	-	USB Data-(CQM748-0-50-0P/B/U support)
23	CHIP_EN	DI	-	Chip power on
1	GPIO0	DI/DO	VDDIO1	Generic PIO
2	GPIO1	DI/DO	VDDIO1	Generic PIO
3	GPIO2	DI/DO	VDDIO1	Generic PIO
4	GPIO3	DI/DO	VDDIO1	Generic PIO
9	GPIO4	DI/DO	VDDIO1	Generic PIO
8	GPIO5	DI/DO	VDDIO1	Generic PIO
10	GPIO6	DI/DO	VDDIO1	Generic PIO
5	GPIO7	DI/DO	VDDIO1	Generic PIO
6	GPIO8	DI/DO	VDDIO1	Generic PIO
7	GPIO9	DI/DO	VDDIO1	Generic PIO
14	GPIO10	DI/DO	VDDIO1	Generic PIO
13	GPIO11	DI/DO	VDDIO1	Generic PIO
12	GPIO12	DI/DO	VDDIO1	Generic PIO
15	GPIO13	DI/DO	VDDIO1	Generic PIO
16	GPIO14	DI/DO	VDDIO1	Generic PIO
17	GPIO15	DI/DO	VDDIO1	Generic PIO
18	GPIO16	DI/DO	VDD33	Generic PIO
19	GPIO17	DI/DO	VDD33	Generic PIO
20	GPIO18	DI/DO	VDD33	Generic PIO
21	GPIO19	DI/DO	VDD33	Generic PIO
26	GPIO20	DI/DO	VDDIO2	Generic PIO
27	GPIO21	DI/DO	VDDIO2	Generic PIO
28	GPIO22	DI/DO	VDDIO2	Generic PIO
29	GPIO23	DI/DO	VDDIO2	Generic PIO
30	GPIO24	DI/DO	VDDIO2	Generic PIO
31	GPIO25	DI/DO	VDDIO2	Generic PIO
32	GPIO26	DI/DO	VDDIO2	Generic PIO
33	GPIO27	DI/DO	VDDIO2	Generic PIO
35	GPIO28	DI/DO	VDDIO2	Generic PIO
36	GPIO29	DI/DO	VDDIO2	Generic PIO
37	GPIO30	DI/DO	VDDIO2	Generic PIO
38	GPIO31	DI/DO	VDDIO2	Generic PIO

Documentation Title	Documentation No	Revision	Classification	Status	Date
CQM74x Wi-Fi 6/BT/15.4 Module Datasheet		V1.2	Public	Release	Mar 18, 2025

39	GPIO32	DI/DO	VDDIO2	Generic PIO
40	GPIO33	DI/DO	VDDIO2	Generic PIO
41	GPIO34	DI/DO	VDDIO2	Generic PIO

2.2.3 I/O Pin Mux Table

GPIO	QSPI	SDIO	SDH	SPI	I2C (0/1)	UART (0/1)	I2S	PWM	CAN	ADC	DAC	EMAC	DVP	DBI	JTAG
GPIO0				CS	SCL	RTS/CTS/TX/RX	BCLK	CH0P/CH0P	TX/RX	CH9			CAM1_VSYNC		TMS
GPIO1				CLK	SDA	RTS/CTS/TX/RX	FS	CH1P/CH0N	TX/RX	CH8			CAM1_HSYNC		TCK
GPIO2				MISO	SCL	RTS/CTS/TX/RX	DI	CH2P/CH1P	TX/RX	CH2					TDO
GPIO3				MOSI	SDA	RTS/CTS/TX/RX	DO	CH3P/CH1N	TX/RX	CH3			CAM1_DAT0		TDI
GPIO10	SCL	DAT2	DAT1	MISO	SCL	RTS/CTS/TX/RX	DI	CH2P/CH1P	TX/RX	CH7			CAM1_DAT1	B_DB2/C_SDA0	TDO
GPIO11	CS	DAT3	DAT0	MOSI	SDA	RTS/CTS/TX/RX	DO	CH3P/CH1N	TX/RX				CAM1_DAT2	B_DB3/C_DCn	TDI
GPIO12	SDA0	CMD	CLK	CS	SCL	RTS/CTS/TX/RX	BCLK	CH0P/CH2P	TX/RX	CH6			CAM1_DAT3	B_DB4/C_SCL	TMS
GPIO13	SDA1	CLK	CMD	CLK	SDA	RTS/CTS/TX/RX	FS	CH1P/CH2N	TX/RX	CH5			CAM1_CLK	B_DB5/C_CSn	TCK
GPIO14	SDA2	DAT0	DAT3	MISO	SCL	RTS/CTS/TX/RX	DI	CH2P/CH3P	TX/RX	CH4	A_PWM_P		CAM1_DAT4	B_DB6/C_SDA0	TDO
GPIO15	SDA3	DAT1	DAT2	MOSI	SDA	RTS/CTS/TX/RX	DO	CH3P/CH3N	TX/RX		A_PWM_N		CAM1_DAT5	B_DB7/C_DCn	TDI
GPIO16				CS	SCL	RTS/CTS/TX/RX	BCLK	CH0P/CH0P	TX/RX				CAM1_DAT6		TMS
GPIO17				CLK	SDA	RTS/CTS/TX/RX	FS	CH1P/CH0N	TX/RX				CAM1_DAT7		TCK
GPIO18				MISO	SCL	RTS/CTS/TX/RX	DI	CH2P/CH1P	TX/RX						TDO
GPIO19				MOSI	SDA	RTS/CTS/TX/RX	DO	CH3P/CH1N	TX/RX	CH1					TDI
GPIO20				CS	SCL	RTS/CTS/TX/RX	BCLK	CH0P/CH2P	TX/RX	CH0/ACH0					TMS
GPIO21				CLK	SDA	RTS/CTS/TX/RX	FS	CH1P/CH2N	TX/RX	ACH1					TCK
GPIO22				MISO	SCL	RTS/CTS/TX/RX	DI	CH2P/CH3P	TX/RX	ACH2	A_PWM_P				TDO
GPIO23				MOSI	SDA	RTS/CTS/TX/RX	DO	CH3P/CH3N	TX/RX	ACH3	A_PWN_N				TDI
GPIO24				CS	SCL	RTS/CTS/TX/RX	BCLK	CH0P/CH0P	TX/RX				CAM0_DAT0		TMS
GPIO25				CLK	SDA	RTS/CTS/TX/RX	FS	CH1P/CH0N	TX/RX			REF_CLK	CAM0_DAT1		TCK
GPIO26				MISO	SCL	RTS/CTS/TX/RX	DI	CH2P/CH1P	TX/RX			TXD[0]	CAM0_DAT2		TDO
GPIO27				MOSI	SDA	RTS/CTS/TX/RX	DO	CH3P/CH1N	TX/RX	CH10/ACH4	A_PWN_N	TXD[1]	CAM0_DAT3		TDI
GPIO28				CS	SCL	RTS/CTS/TX/RX	BCLK	CH0P/CH2P	TX/RX	CH11/ACH5	A_PWM_P	RXD[0]	CAM0_HSYNC		TMS
GPIO29				CLK	SDA	RTS/CTS/TX/RX	FS	CH1P/CH2N	TX/RX	ACH6		RXD[1]	CAM0_VSYNC		TCK
GPIO30				MISO	SCL	RTS/CTS/TX/RX	DI	CH2P/CH3P	TX/RX	ACH7		RXERR	CAM0_CLK		TDO
GPIO31				MOSI	SDA	RTS/CTS/TX/RX	DO	CH3P/CH3N	TX/RX			TX_EN	CAM0_DAT4		TDI
GPIO32				CS	SCL	RTS/CTS/TX/RX	BCLK	CH0P/CH0P	TX/RX			RX_DV	CAM0_DAT5		TMS
GPIO33				CLK	SDA	RTS/CTS/TX/RX	FS	CH1P/CH0N	TX/RX			MDC	CAM0_DAT6		TCK
GPIO34				MISO	SCL	RTS/CTS/TX/RX	DI	CH2P/CH1P	TX/RX			MDIO	CAM0_DAT7		TDO

Documentation Title	Documentation No	Revision	Classification	Status	Date
CQM74x Wi-Fi 6/BT/15.4 Module Datasheet		V1.2	Public	Release	Mar 18, 2025

2.3 Computing Subsystem

CQM74x has Qualcomm QCC744/QCC748 at his core which integrates 32-bit RISC-V @325MHz, 128KB ROM and 484KB SRAM as well as on-module NOR flash with size up to 8MB. The code can be executed from flash via Execution-in-Place (XiP).

Qualcomm	pSRAM Built-in	Flash Built-in	Grade	Package
QCC744	4MB	X	-40~85°C	QFN-56, 7 x 7 x 0.9 mm, 0.4 mm pitch
QCC748	4MB	X	-40~85°C	QFN-56, 7 x 7 x 0.9 mm, 0.4 mm pitch

The computing subsystem software architecture is shown below:

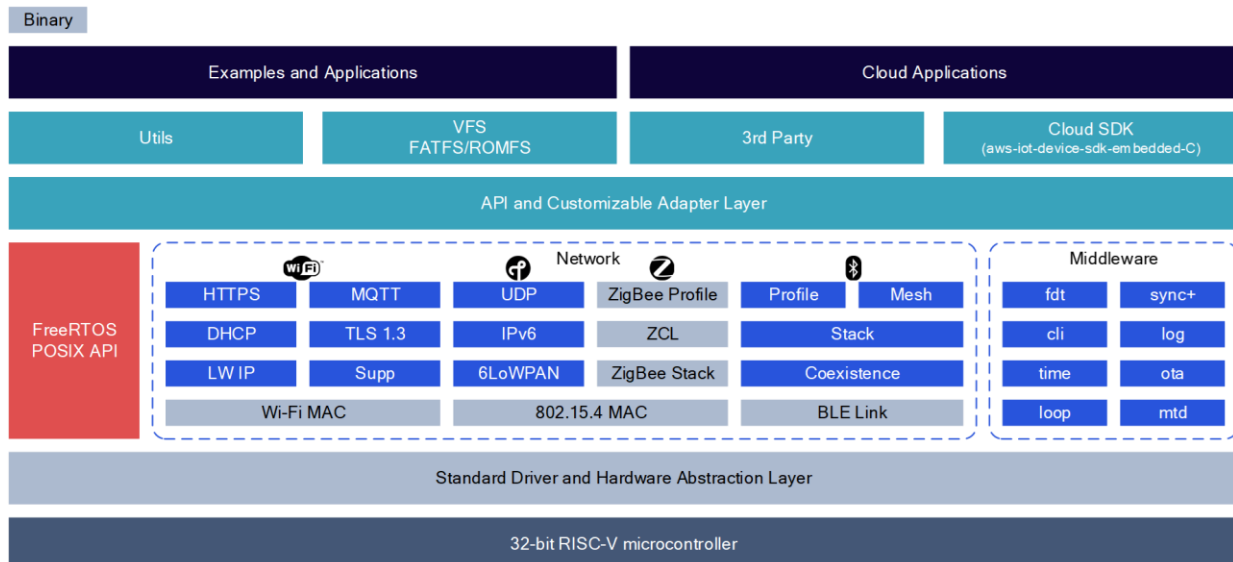

Figure 8: Computing Subsystem Software Architecture

Software SDK will be open sourced at Codelinaro with blocks in dot line will be offered in binary format inside software SDK package.

Codelinaro Download Link: <https://git.codelinaro.org/clo/qcc7xx/QCCSDK-QCC74x>

Documentation Title	Documentation No	Revision	Classification	Status	Date
CQM74x Wi-Fi 6/BT/15.4 Module Datasheet		V1.2	Public	Release	Mar 18, 2025

3 Electrical Characteristics

3.1 Absolute Maximum Ratings

The absolute maximum ratings provided in this section reflect the stress levels that, if exceeded, may cause permanent damage to the device. No functionality is guaranteed outside the operating specifications. Functionality and reliability are only guaranteed within the operating specifications.

Pin	Parameter	Min	Max	Unit
VDD33	Power input voltage	-0.3	3.63	V
VDDIO1, VDDIO 2	I/O port voltage	-0.3	3.63	V
ESD Protection (HBM)	-	-	2,000	V
Storage temperature	-	-40	135	°C

3.2 Recommended Operating Conditions

Pin	Parameter	Min	TYP	Max	Unit
VDD33	Power input voltage	2.97	3.3	3.63	V
VDDIO1, VDDIO 2 (3.3V)	I/O port voltage	2.97	3.3	3.63	V
VDDIO1, VDDIO 2 (1.8V)	I/O port voltage	1.62	1.8	1.98	V
Operating temperature	-	-40	-	85	°C
Storage temperature	-	-40	-	135	°C

Documentation Title	Documentation No	Revision	Classification	Status	Date
CQM74x Wi-Fi 6/BT/15.4 Module Datasheet		V1.2	Public	Release	Mar 18, 2025

4 Radio Performance

The radio performance for Wi-Fi, Bluetooth and 802.15.4 is shown in the table below:

4.1 802.11b/g/n/ax (Wi-Fi 6)

Standard	PHY	Modulation	MCS Index	Data Rate (Mbps)		Max Tx Power (dBm)		Rx Sensitivity (dBm)	
				HE20	HE40	HE20	HE40	HE20	HE40
802.11b	CCK (DSSS)	DBPSK	-	1		21		-99.0	
	CCK (DSSS)	DQPSK	-	2		21		-96.5	
	CCK (DSSS)	B/DQPSK	-	5.5		21		-94.5	
	CCK (DSSS)	Q/DQPSK	-	11		21		-90.0	
802.11g	OFDM	BPSK	-	6		20		-93.0	
	OFDM	BPSK	-	9		20		-92.5	
	OFDM	QPSK	-	12		20		-91.5	
	OFDM	QPSK	-	18		20		-89.0	
	OFDM	16QAM	-	24		19		-86.5	
	OFDM	16QAM	-	36		19		-83.0	
	OFDM	64QAM	-	48		18		-89.0	
	OFDM	64QAM	-	54		18		-77.5	
802.11n	OFDM	BPSK	MCS0	7.2	15	19	18	-93.0	-89.5
	OFDM	QPSK	MCS1	14.4	30	19	18	-91.0	-88.0
	OFDM	QPSK	MCS2	21.7	45	19	18	-89.0	-86.0
	OFDM	16QAM	MCS3	28.9	60	19	18	-86.5	-83.5
	OFDM	16QAM	MCS4	43.3	90	19	18	-83.0	-80.5
	OFDM	64QAM	MCS5	57.8	120	18	17	-79.0	-76.5
	OFDM	64QAM	MCS6	65	135	18	17	-77.5	-75.0
	OFDM	64QAM	MCS7	72.2	150	18	17	-76.0	-73.0
802.11ax	OFDMA	BPSK	MCS0	8.6	17.2	19	19	-93.0	-89.5
	OFDMA	QPSK	MCS1	17.2	34.4	19	19	-91.0	-88.0

Documentation Title	Documentation No	Revision	Classification	Status	Date
CQM74x Wi-Fi 6/BT/15.4 Module Datasheet	V1.2	Public	Release	Mar 18, 2025	

	OFDMA	QPSK	MCS2	25.8	51.6	19	19	-89.0	-86.5
	OFDMA	16QAM	MCS3	34.4	68.8	19	19	-86.0	-83.5
	OFDMA	16QAM	MCS4	51.6	103.2	19	19	-83.0	-80.0
	OFDMA	64QAM	MCS5	68.8	137.6	18	16	-79.0	-76.5
	OFDMA	64QAM	MCS6	77.4	154.9	18	16	-77.5	-75.0
	OFDMA	64QAM	MCS7	86	172.1	18	16	-75.5	-73.0
	OFDMA	256QAM	MCS8	103.2	206.5	17	16	-72.0	-69.0
	OFDMA	256QAM	MCS9	114.7	229.4	17	16	-70.0	-67.0

4.2 Bluetooth

Standard	PHY	Modulation	Data Rate	Max Tx Power (dBm)	Rx Sensitivity (dBm)
BT Classic	BR	GFSK	1Mbps	+10	-94
	EDR	$\pi/4$ DQPSK	2Mbps	+10	-96
	EDR	8DPSK	3Mbps	+8	-90
BLE	LE 2M	GFSK	2Mbps	+10	-97
	LE 1M	GFSK	1Mbps	+10	-99
	LE Coded (S=2)	GFSK	500Kbps	+10	-102
	LE Coded (S=8)	GFSK	125Kbps	+10	-105

4.3 802.15.4

Standard	Modulation	Data Rate	Max Tx Power (dBm)	Rx Sensitivity (dBm)
802.15.4	DSSS O-QPSK MPSK GFSK BPSK	250Kbps	+20	TBD

Documentation Title	Documentation No	Revision	Classification	Status	Date
CQM74x Wi-Fi 6/BT/15.4 Module Datasheet		V1.2	Public	Release	Mar 18, 2025

5 Power Consumption

CQM74x can operate in four power states as shown below to maximize power saving:

- Active – Continuous transmitting or receiving on connection to AP
- Idle – No active transmitting or receiving. CPU is in idle state.
- Deep Sleep – Wi-Fi/USB/CPU/Peripherals power off. This is DTIM power saving mode
- Hibernation – No connection to AP.
- Shut down – the chip is completely shut down

The power consumption for each state is listed in the table below:

Operation Mode	State	Typical	Unit	Comments
Active	MCU Active & Rx Active	38	mA	MCU 160MHz, XCLK 40MHz, BCLK 80MHz, Flash 40MHz
	Tx Active	326	mA	MCS0, HT20 Tx Power = +19 dBm
Power Saving	Deep Sleep	64	μA	Wi-Fi/USB/CPU/Peripherals Power Off. This is DTIM PS mode
	Hibernation	2.1	μA	4KB RAM retained
	Shut Down	0.15	μA	
DTIM	DTIM 1	476	μA	Xtal32k
		524	μA	RC 32k
	DTIM 3	179	μA	Xtal32k
		227	μA	RC 32k
	DTIM 5	119	μA	Xtal32k
		167	μA	RC 32k
	DTIM 10	75	μA	Xtal32k
		123	μA	RC 32k

Documentation Title	Documentation No	Revision	Classification	Status	Date
CQM74x Wi-Fi 6/BT/15.4 Module Datasheet		V1.2	Public	Release	Mar 18, 2025

6 Mechanical Specification

6.1 Pin Antenna

6.1.1 Dimension

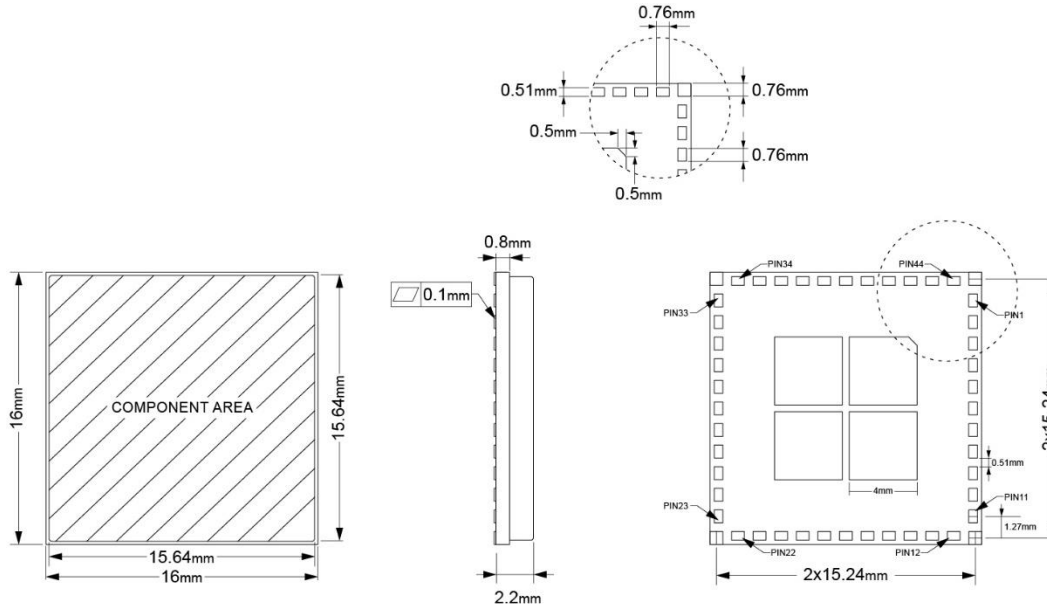

Figure 9: CQM74x-0-50-0P Module Dimension

6.1.2 Recommended PCB Landing Pattern

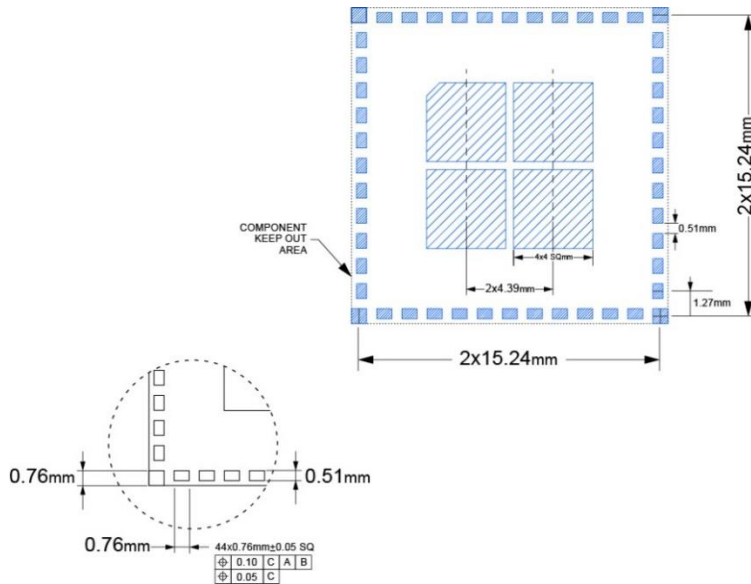

Figure 10: CQM74x-0-50-0P Module PCB Landing Pattern

Documentation Title	Documentation No	Revision	Classification	Status	Date
CQM74x Wi-Fi 6/BT/15.4 Module Datasheet		V1.2	Public	Release	Mar 18, 2025

6.2 PCB Antenna

6.2.1 Dimension

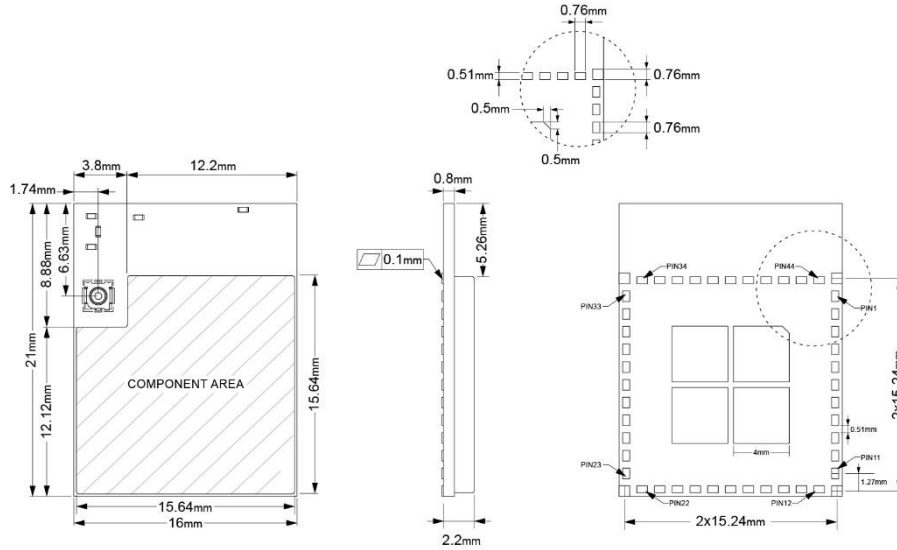

Figure 11: CQM74x-0-50-0B Module Dimension

6.2.2 Recommended PCB Landing Pattern

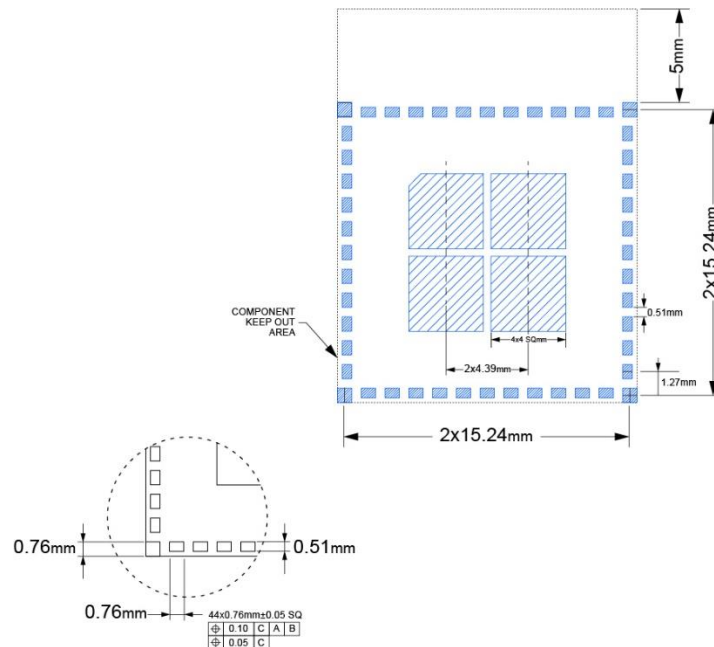

Figure 12: CQM74x-0-50-0B Module PCB Landing Pattern

Documentation Title	Documentation No	Revision	Classification	Status	Date
CQM74x Wi-Fi 6/BT/15.4 Module Datasheet		V1.2	Public	Release	Mar 18, 2025

6.3 Connector Antenna

6.3.1 Dimension

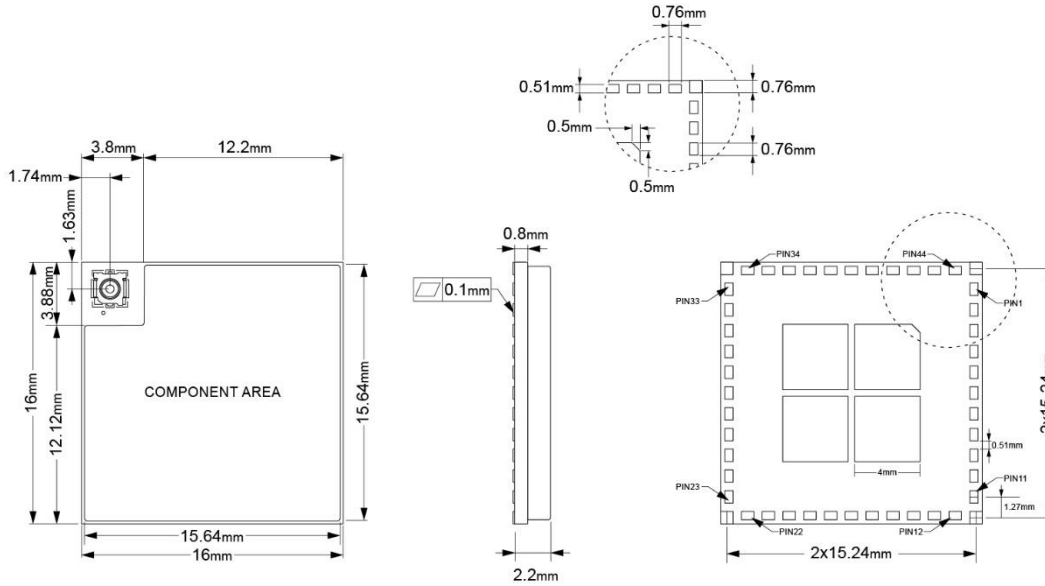

Figure 13: CQM74x-0-50-0U Module Dimension

6.3.2 Recommended PCB Landing Pattern

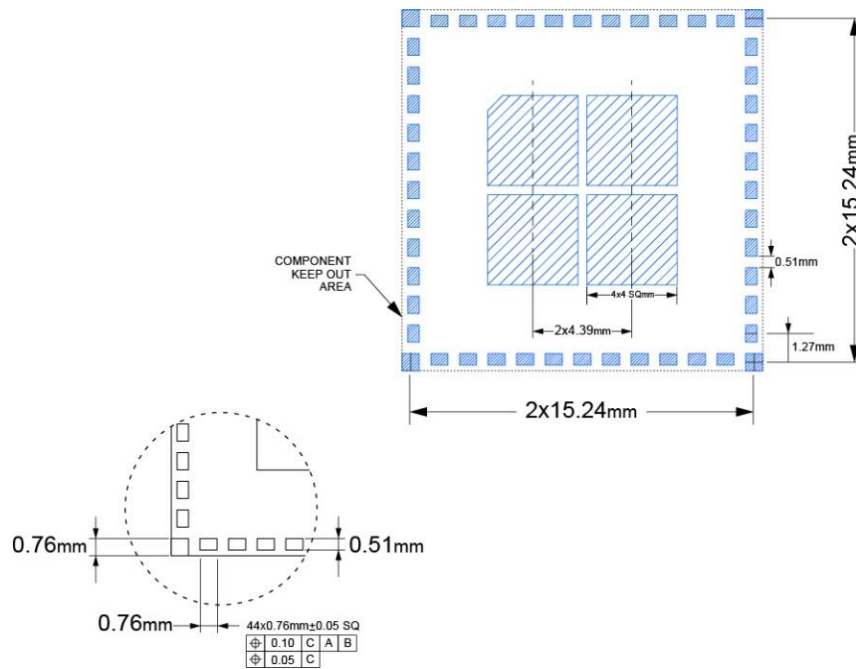

Figure 14: CQM74x-0-50-0U Module PCB Landing Pattern

Documentation Title	Documentation No	Revision	Classification	Status	Date
CQM74x Wi-Fi 6/BT/15.4 Module Datasheet		V1.2	Public	Release	Mar 18, 2025

7 Manufacturing Recommendation

7.1 Power Layout Guideline

CQM74x is powered by either 3V battery or DC 3.3V. Power pin connection capacitor is as close as possible to chip and pin. Decoupling the power supply from the chip using a capacitor. Use capacitors to prevent noise from coupling back to the power plane.

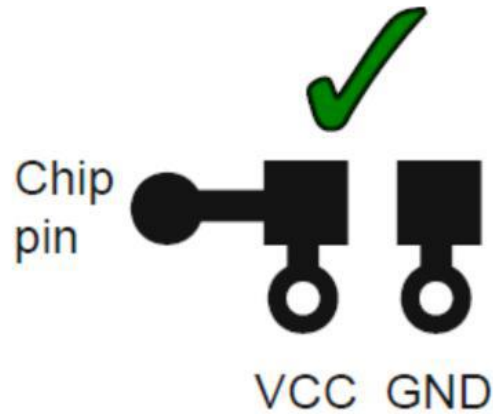

Figure 15: Power Layout Guideline

7.2 Soldering Recommendations

CQM74x can be SMT on the board following the temperature curve graph:

Documentation Title	Documentation No	Revision	Classification	Status	Date
CQM74x Wi-Fi 6/BT/15.4 Module Datasheet		V1.2	Public	Release	Mar 18, 2025

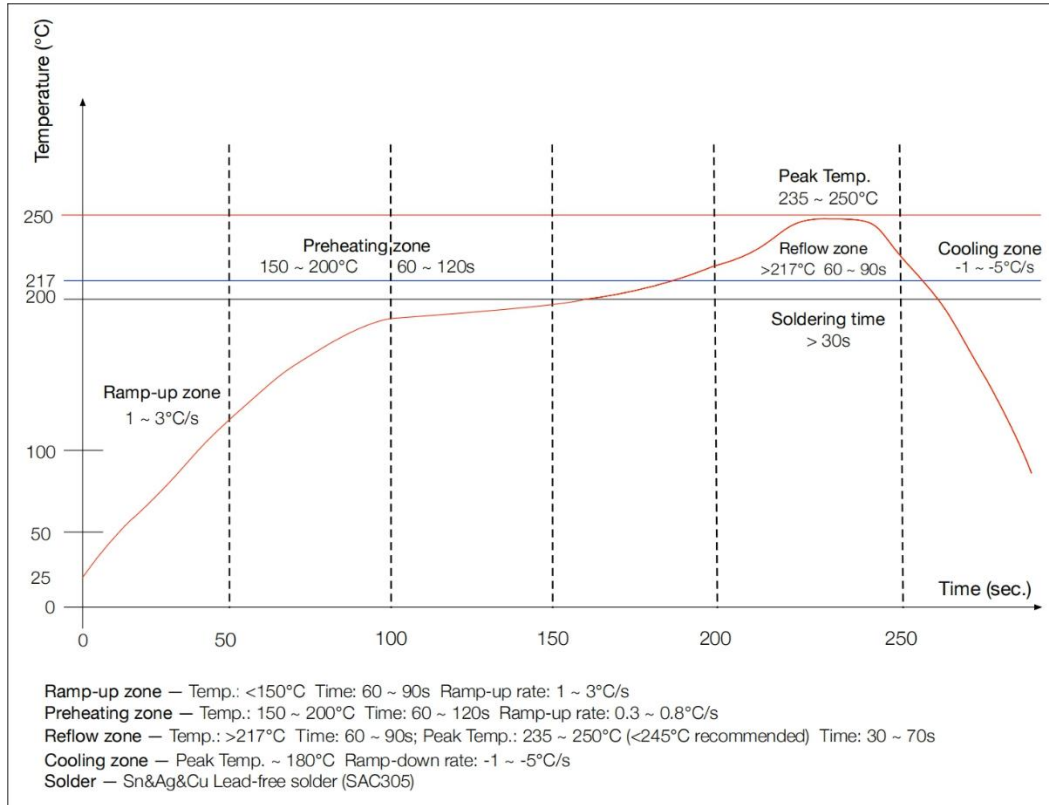

Figure 16: Soldering Guideline

Documentation Title	Documentation No	Revision	Classification	Status	Date
CQM74x Wi-Fi 6/BT/15.4 Module Datasheet		V1.2	Public	Release	Mar 18, 2025

Revision History

Revision	Description	Date
1.0	Initial draft	July 1, 2024
1.1	Update size and pin map	Jan 14, 2025
1.2	Update Module name	Mar 18, 2025

Documentation Title	Documentation No	Revision	Classification	Status	Date
CQM74x Wi-Fi 6/BT/15.4 Module Datasheet		V1.2	Public	Release	Mar 18, 2025

Disclaimer and Copyright Notice

Information in this document, including URL references, is subject to change without notice.

THIS DOCUMENT IS PROVIDED AS IS WITH NO WARRANTIES WHATSOEVER, INCLUDING ANY WARRANTY OF MERCHANTABILITY, NON-INFRINGEMENT, FITNESS FOR ANY PARTICULAR PURPOSE, OR ANY WARRANTY OTHERWISE ARISING OUT OF ANY PROPOSAL, SPECIFICATION OR SAMPLE.

All liability, including liability for infringement of any proprietary rights, relating to the use of information in this document, is disclaimed. No licenses express or implied, by estoppel or otherwise, to any intellectual property rights are granted herein.

Copyright©2025 Creatcomm. All rights reserved.